

HAFCO

DELUXE SERIES



Swivel Castors



Height Adjustable



Tool Tray Holder

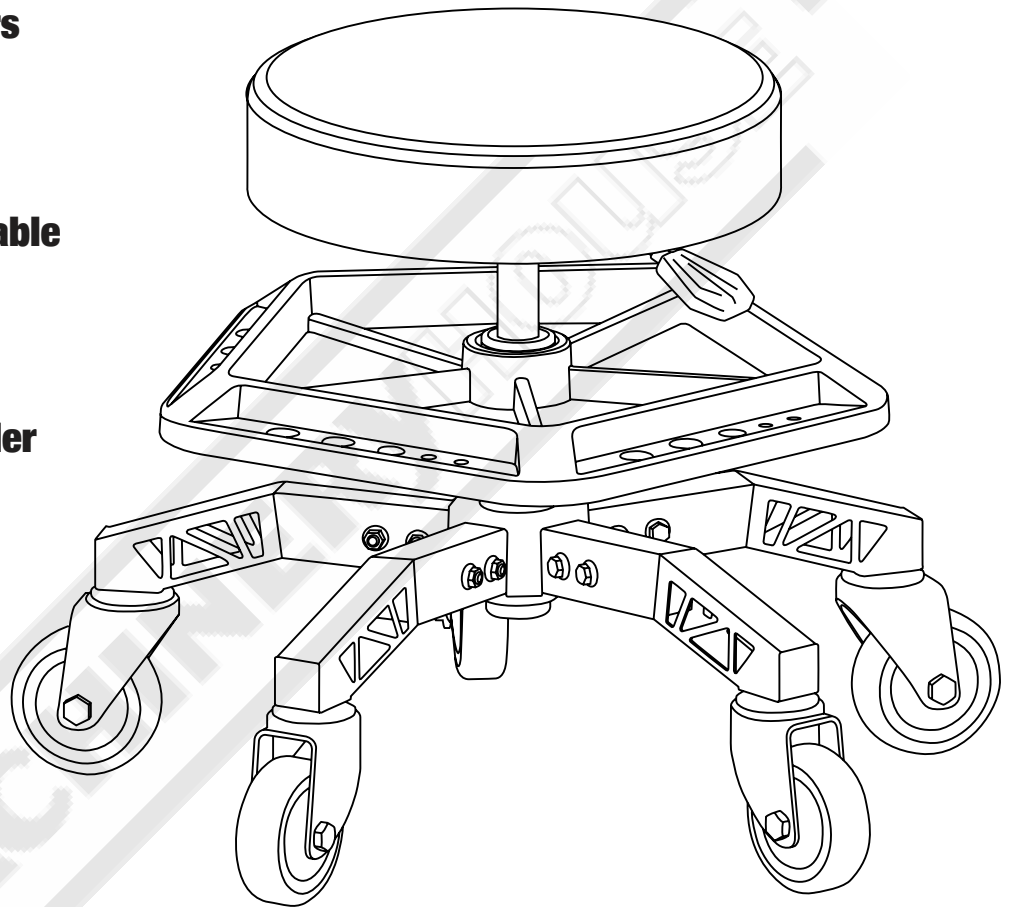

Edition : 1.0
Date: (8/05/24)

Instruction Manual

MECHANICS ROLLER SEAT DELUXE SERIES

Order Code: (A361)

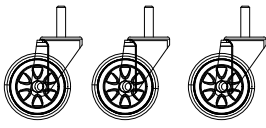

1. Universal Wheel (x 3)

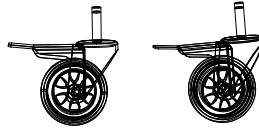

2. Universal Wheel with Brake (x 2)

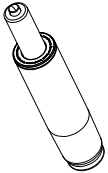

3. Pneumatic Cylinder

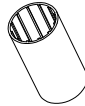

4. Spacer

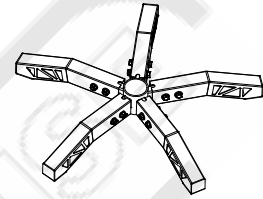

5. Bottom Frame

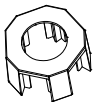

6. Decorative Cover



7. Cushion Seat

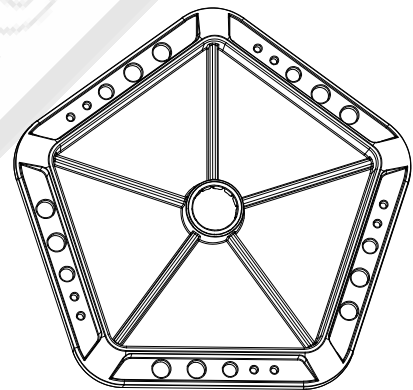

8. Tool Tray

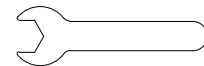

9. Opn Wrench

Part No.	Description	Quantity
1	Universal Wheel	3
2	Universal Wheel with brake	2
3	Pneumatic Cylinder	1
4	Spacer	1
5	Bottom Frame	1
6	Decorative Cover	1
7	Cushion Seat	1
8	Tool Tray	1
9	Open End Wrench	1

STEP 1

Install all universal wheels (1 & 2) by screwing them into the bottom frame threaded holes (5) . Use a wrench to tighten all wheels.

Part No.	Description	Quantity
1	Universal Wheel	3
2	Universal Wheel with brake	2
5	Bottom Frame	1

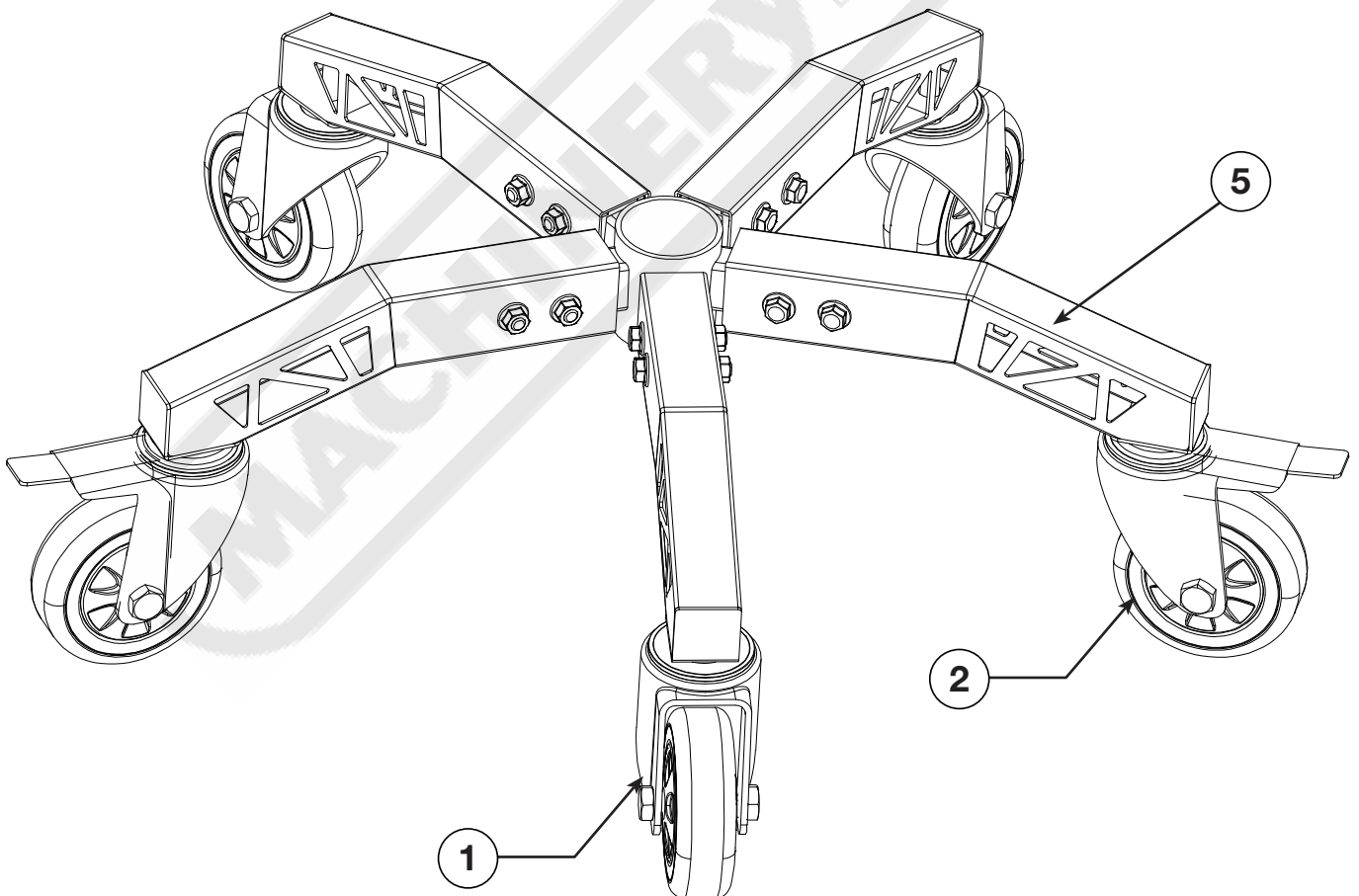

STEP 2

Install the decorative cover (6) onto the top of the frame (5) as shown below.

Part No.	Description	Quantity
6	Decorative Cover	1

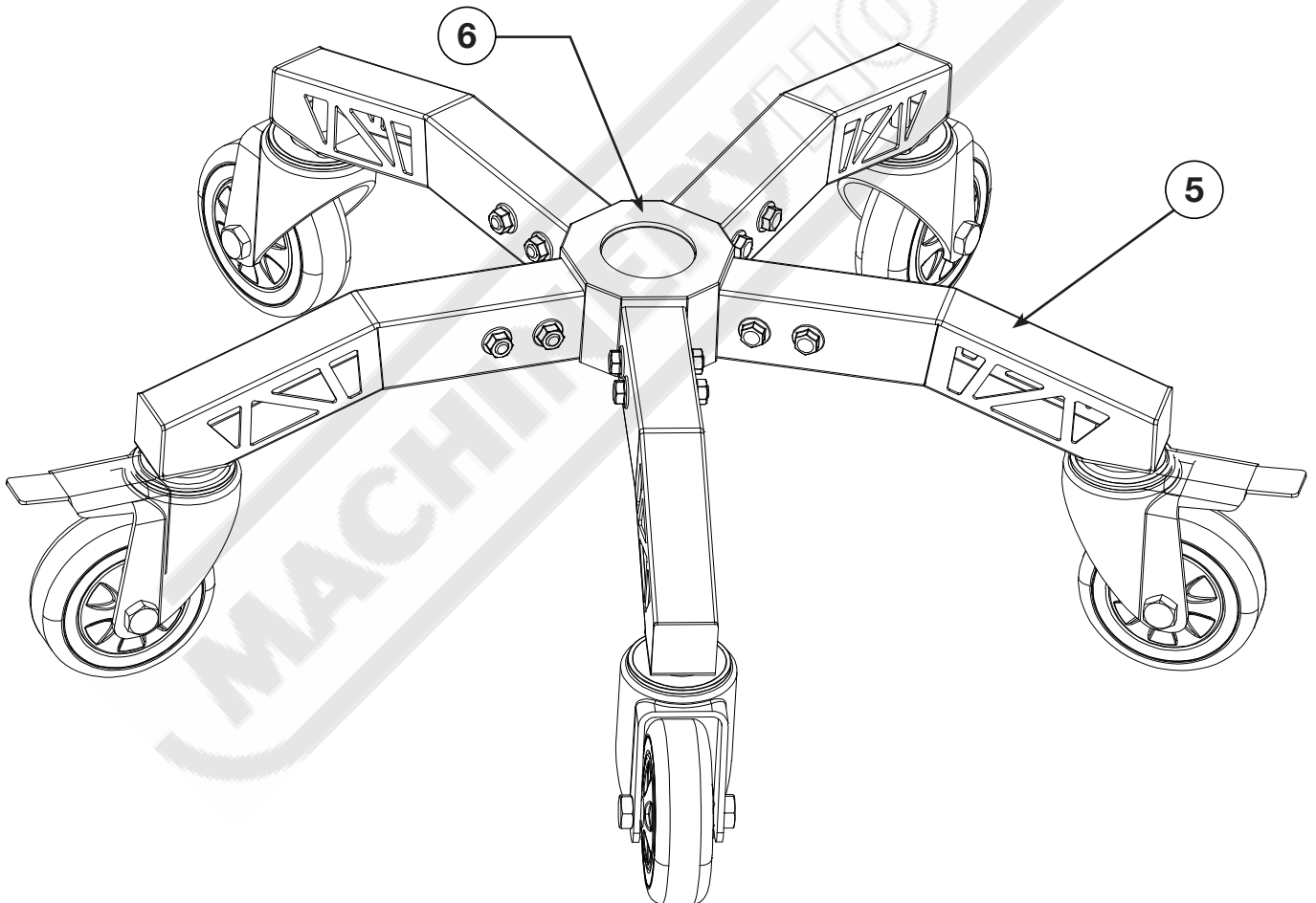

STEP 3

Align the smaller end of the spacer (4) with the tool tray (8) and press on firmly to fit together.

Part No.	Description	Quantity
4	Spacer	1
8	Tool Tray	1

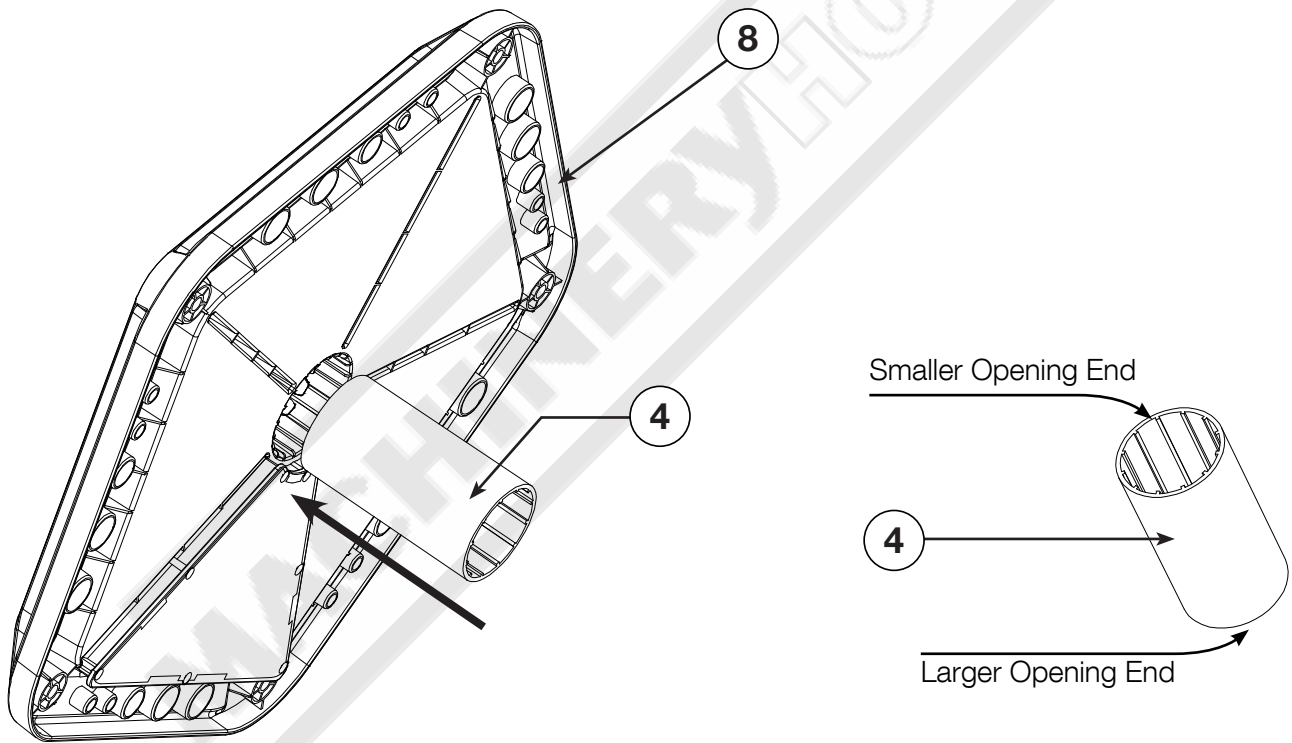

STEP 4

Remove the rubber sleeve on the pneumatic cylinder and then insert the larger end into the top of the tool tray (8).

Part No.	Description	Quantity
3	Pneumatic Cylinder	1

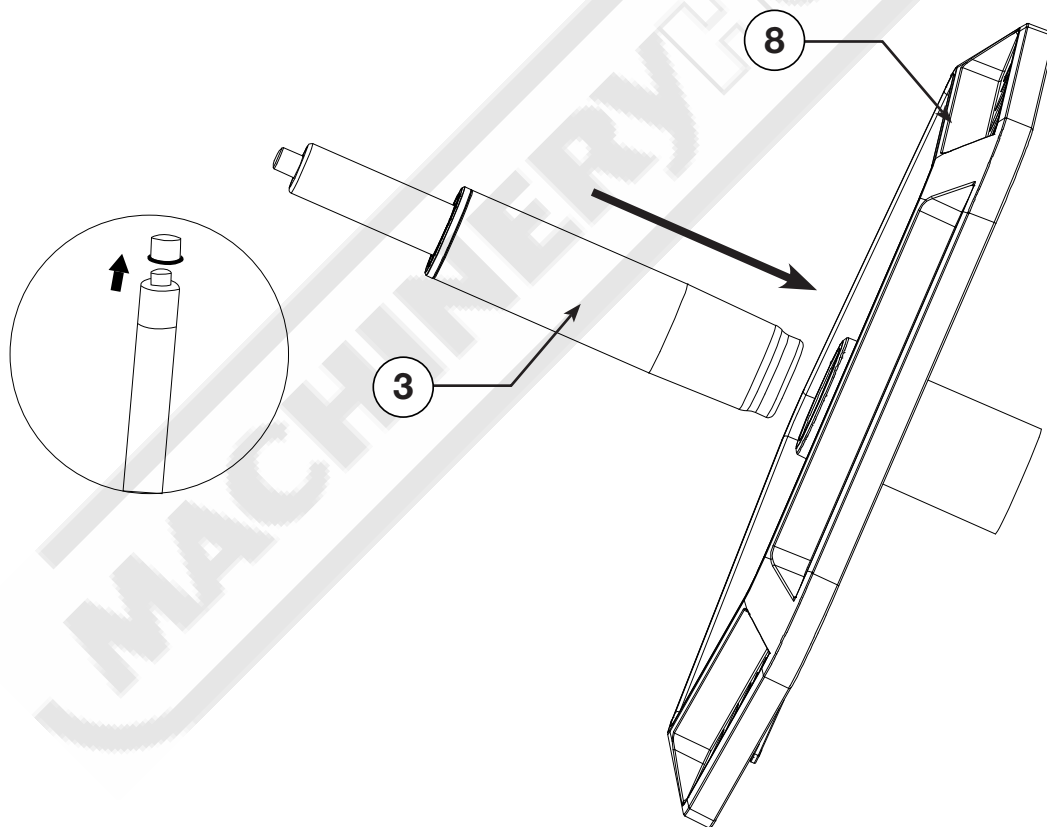

STEP 5

Install the pneumatic cylinder (3) into the bottom frame (5) as shown below.

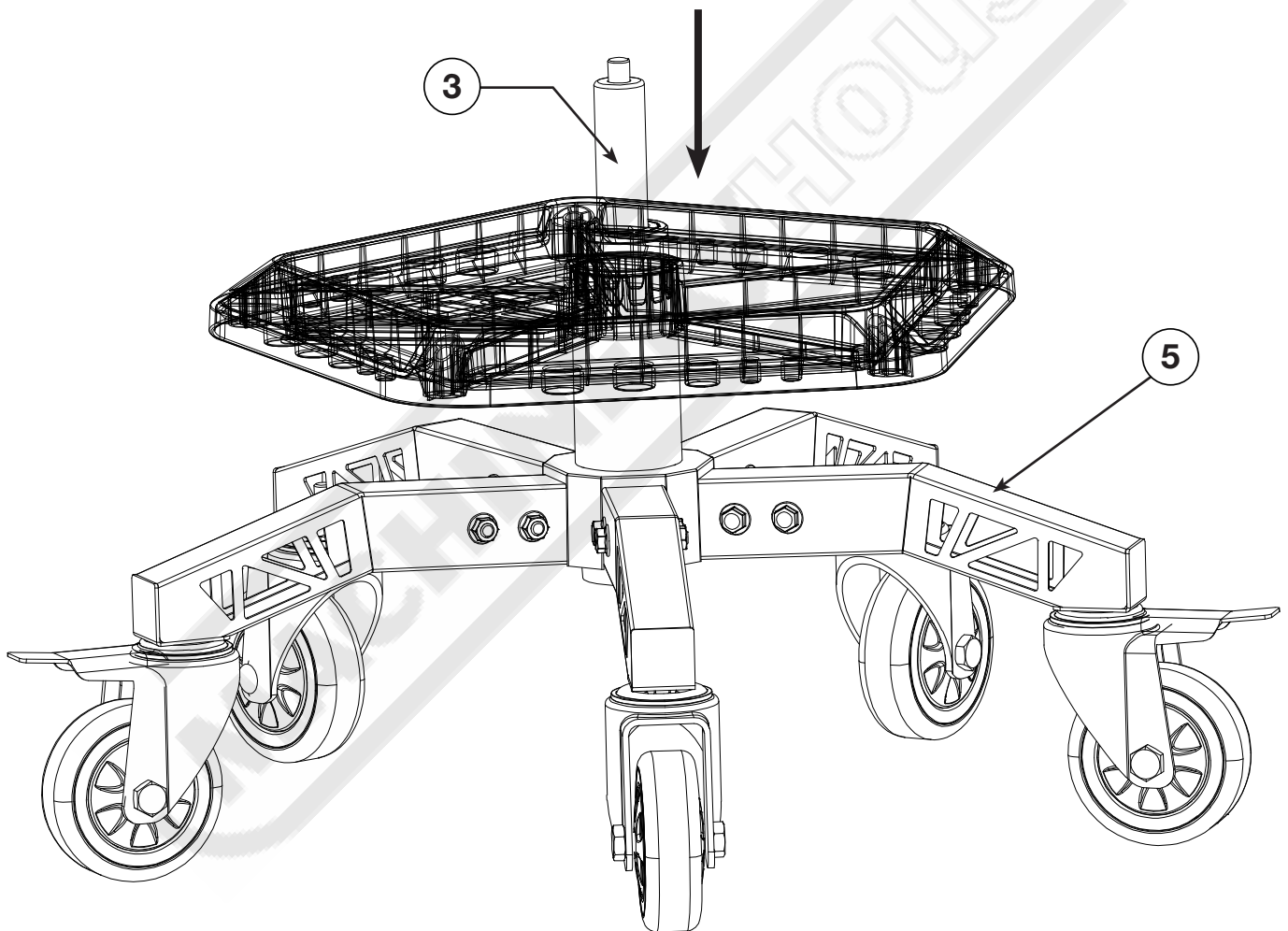

STEP 6

Align the cushion seat (7) with the top rod of the pneumatic cylinder (3) and press into place.

Part No.	Description	Quantity
7	Cushion Seat	1

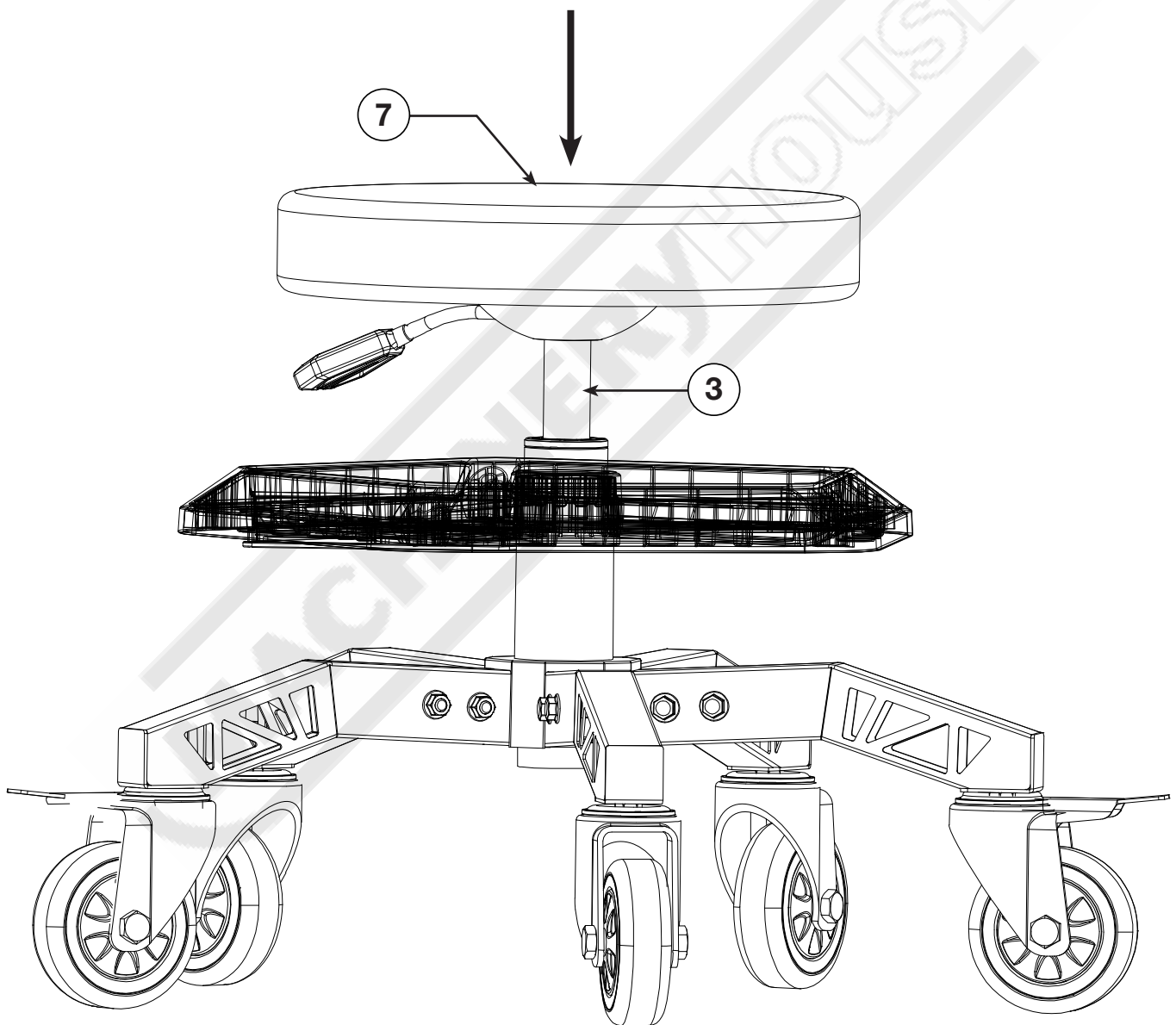

Note: It is our policy to continually improve products and as such we reserve the right to alter data, specifications and component parts without prior notice.

Important: No Liability is accepted for incorrect use of this product.

Warranty: Guarantee is 12 months from purchase date, proof of which is required for any claim.

DISTRIBUTED BY

MACHINERYHOUSE

www.machineryhouse.com.au

www.machineryhouse.co.nz